

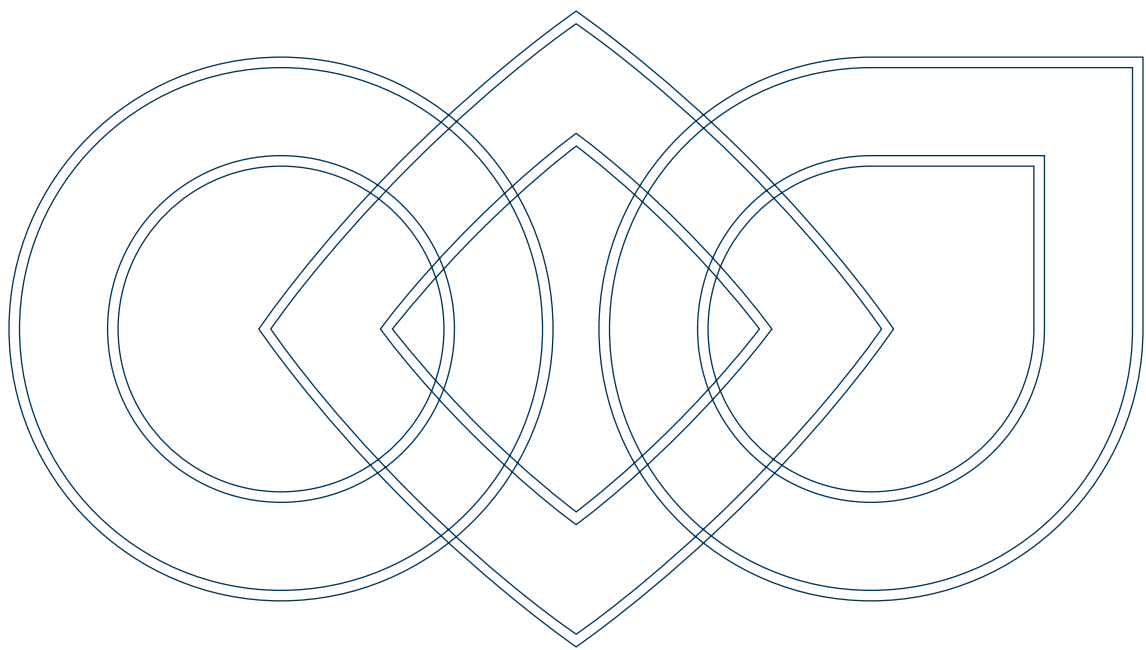

MOBILE

PRODUCTS
RANGE MOBILE



A complete range of innovative products for mobile solutions.

For over 40 years, the “Mobile” sector has been one of the cornerstones on which the Bonfiglioli Group’s growth and internationalisation has been founded.

Our wide range of planetary gearboxes - complete with hydraulic and electric motors for excavators, roadwork equipment and many other applications - are manufactured in a production process which is firmly focussed on the specific needs of our customers.

These are products with the highest levels of customisation, which require, right from the initial design phases, in-depth interaction between the customer and Bonfiglioli, to ensure that all of the

required specifications and variants are known, for a product which perfectly meets expectations.

This is why our pre-sales and after-sales teams, spread strategically over all continents, play such a crucial role, and why ensuring complete support is at the heart of our global success.

In the immediate future, Bonfiglioli is ready to offer innovative electromobility solutions for mobile equipment in a huge range of contexts.

This choice is perfectly in line with the industrial philosophy of the future, which is increasingly placing electrical systems alongside traditional power transmission.



BONFIGLIOLI MOBILE



Specific solutions for power transmission and motion control.



Product diversification, process automation, and quality have enabled Bonfiglioli to play a leading role in the industry.

Bonfiglioli's policy focuses on integrated solutions, competence and innovative technology as key factors, indispensable to ensure customer satisfaction, while

production is aimed at achieving the highest standards.

Bonfiglioli product portfolio aims at meeting the toughest and most sophisticated requirement for Industrial Process and Automation Solution and for Mobile Equipment Solutions.



BONFIGLIOLI PRODUCTS

Product offer

PLANETARY DRIVES

8 300 series

TRANSIT MIXER DRIVES

10 500 series

WHEEL DRIVES

12 600 series

14 600E series

16 PGW series

18 600W2/3

TRAVEL DRIVES

20 700C series

TRACK DRIVE GEARMOTORS

22 700CK series

24 PGR series

26 700CT series

DRUM DRIVES FOR MILLING MACHINE

28 700C series

SLEW DRIVES

30 700T series

32 700TK series

WINCH DRIVES

34 800 series

36 OUR QUALITIES

38 WORLDWIDE NETWORK

300 series Planetary drives

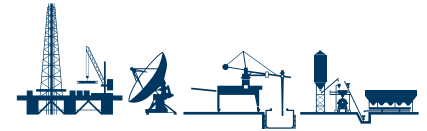

The powerful solution to all heavy duty drive problems.

The 300 series are compact and powerful. Their planetary drive train makes them the ideal choice for all the severe duty applications where shock loads and impacts are more the rule than the exception. The product configuration is highly versatile, due to several options as far as the mounting, the gear layout, the output shaft and the motor interface. All the features are available for each of the 20 finely spaced frame sizes, spanning over the 1000 - 1100000 Nm torque range. Finding the perfect match to any drive problem is therefore more than a wish, it is something users can safely rely on - always.



Torque Range

1000 ... 1100000 Nm

Transmissible Mechanical Power

up to 1050 kW

Gear Ratios

3.4 ... 5000

Gear Unit Versions

In line
Right angle (with a spiral bevel gear set)

Output Configuration

Foot and flange mounted
Output shaft: solid with key, splined, splined hollow, hollow with shrink disc

Input Configurations

Flanged axial piston hydraulic motors
Hydraulic orbit motors
IEC and Nema motor adaptors
Solid input shaft

Hydraulic Brake

Hydraulically released parking brake on request

Electric Brake

DC and AC type

Type	Torque (Nm)
300	1000
301	1750
303	2500
304	3600
305	5000
306	8500
307	12500
309	18000
310	25000
311	40000
313	55000
314	80000
315	100000
316	135000
317	170000
318	250000
319	350000
321	500000
323	800000
325	1100000

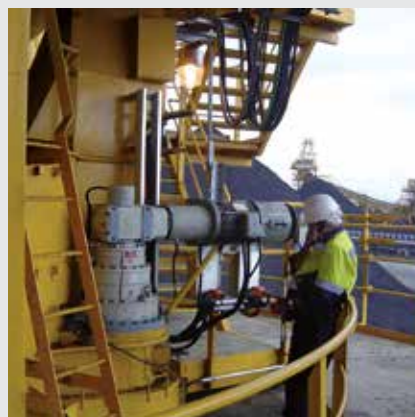

Overall dimensions and technical data

TYPE	MAX POWER	MAX INPUT SPEED				DESIGN
			Inline	Right angle	Combined with worm gear	
	kW	RPM				
300	20	3000	3.4 - 2700	7 - 700	400 - 2300	A
301	30	3000	3.4 - 2700	7 - 700	400 - 2300	A
303	40	3000	3.6 - 2800	9 - 800	400 - 2400	A
304	50	3000	3.6 - 2500	9 - 700	400 - 2400	A
305	60	3000	3.6 - 2800	9 - 800	400 - 2400	A
306	75	2500	3.6 - 2900	9 - 800	400 - 2600	A
307	100	2500	3.4 - 2400	13 - 700	400 - 2500	A
309	130	2500	3.4 - 2400	13 - 700	400 - 2500	B
310	150	2000	4 - 2500	40 - 900	400 - 5000	B
311	180	2000	4 - 2100	18 - 800	400 - 5000	B
313	200	2000	4 - 2200	18 - 800	400 - 5000	B
314	225	2000	4 - 1800	50 - 600	400 - 5000	B
315	250	1500	4 - 1800	70 - 900	400 - 5000	B
316	270	1500	4.4 - 1200	50 - 600	400 - 5000	B
317	300	1000	4 - 1900	70 - 900	400 - 5000	B
318	340	1000	4.4 - 1100	200 - 700	400 - 5000	B
319	380	500	4.8 - 1400	300 - 800	2500 - 5000	B
321	450	300	4.4 - 1100	300 - 800	1000 - 5000	B
323	850	300	4.6 - 1300	-	-	B
325	1050	300	4.6 - 1300	-	-	B

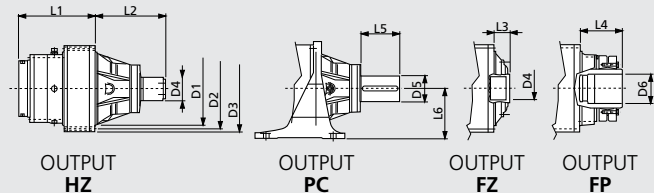
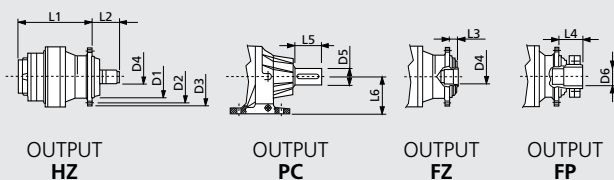
DESIGN A • 300 - 307
DESIGN B • 309 - 325

TYPE	D1	D2	D3	D4	D5	D6	L1 (2 stages)	L2	L3	L4	L5	L6
300	110	165	185	40x36 DIN 5482	38	42	168	61	14	50	58	100
301	110	165	185	40x36 DIN 5482	50	42	180	61	14	50	82	132
303	150	195	222	58x53 DIN 5482	60	75	200	83	15	85	105	160
304	150	195	222	58x53 DIN 5482	60	75	212	83	15	85	105	160
305	150	195	222	58x53 DIN 5482	60	75	230	83	15	85	105	160
306	200	250	280	70x64 DIN 5482	80	90	260	130	40	115	130	180
307	230	295	325	80x74 DIN 5482	90	100	300	162	36	120	170	200
309	278	314	348	80x74 DIN 5482	100	120	215	231	82	245	165	225
310	340	370	400	100x94 DIN 5482	110	130	245	290	95	290	210	250
311	358	390	428	100x94 DIN 5482	120	135	250	320	88	190	210	280
313	385	415	445	120x3 DIN 5480	140	145	310	357	81	235	200	280
314	460	503	542	150x5 DIN 5480	160	180	370	429	98	260	240	315
315	460	503	542	150x5 DIN 5480	160	180	390	429	98	260	240	315
316	580	625	670	170x5 DIN 5480	180	180	430	275	145	265	260	400
317	560	635	695	200x5 DIN 5480	200	260	470	352	152	318	260	415
318	700	750	800	220x5 DIN 5480	250	220	550	340	155	305	330	500
319	800	880	940	260x5 DIN 5480	280	350	570	470	210	440	380	550
321	940	1020	1100	300x8 DIN 5480	340	390	595	500	250	440	540	650
323	1100	1220	1300	400x8 DIN 5480	-	410	666	-	375	520	-	-
325	1260	1380	1460	450x8 DIN 5480	-	450	698	-	400	590	-	-

500 series

Transit mixer drives



When you cannot afford any down time, then quality is the top priority.

Absolute dependability, low maintenance, compactness and price effectiveness are the key features of the renovated 500 series, the unparalleled line of drives for transit mixers. Eight models available for mixing capacity ranging from 1 to 14 m³.



Torque Range

3000 ... 90000 Nm

Truck mixer capacity

1 to 14 cubic meters

Gear Ratios

17 ... 161

Key Features

- Rotating housing flange
- Rugged design
- High torque capacity
- High load capacity
- Tilting output flange, evenly in all directions
- Mounting frame for water tank
- Water pump P.T.O.
- Speed sensor

Applicable hydraulic motors

- Axial piston motors to SAE
- Standard orbit motors

Type	Torque (Nm)
501	3000
564	12000
565	12000
567	20000
568	20000
575	50000
577	60000
580	75000



Overall dimensions and technical data

TYPE	RANGE OF RATIOS	HYDR. MOTOR DRIVE ⁽¹⁾	MAX. INPUT SPEED	DRUM CAPACITY ⁽²⁾	WEIGHT	OIL QUANTITY	DESIGN	WATER PUMP P.T.O.	SPEED SENSOR
	1:		min ⁻¹	m ³	kg	L			
501	17-23-29	LS	550	0.5 - 1	45	1.5	A	–	–
564	78-161	HS	2500	2 - 3	85	2	A	–	–
565	22	LS	550	2 - 3	70	1.5	A	–	–
567	76-90-115-128	HS	2500	4 - 5	140	3	A	–	–
568	18-21-27	LS	550	4 - 5	130	2.5	A	–	–
575	99.3-102-141	HS	3000	6 - 8	250	7	B	•	•
577	131	HS	3000	8 - 10	290	8.5	B	•	•
580	130-135-140	HS	3000	10 - 14	320	10	B	•	•

(1) **LS** = Low speed motor / **HS** = High speed motor

(2) General indication, application capacity depend on concrete slump

– = Not available

• = Available

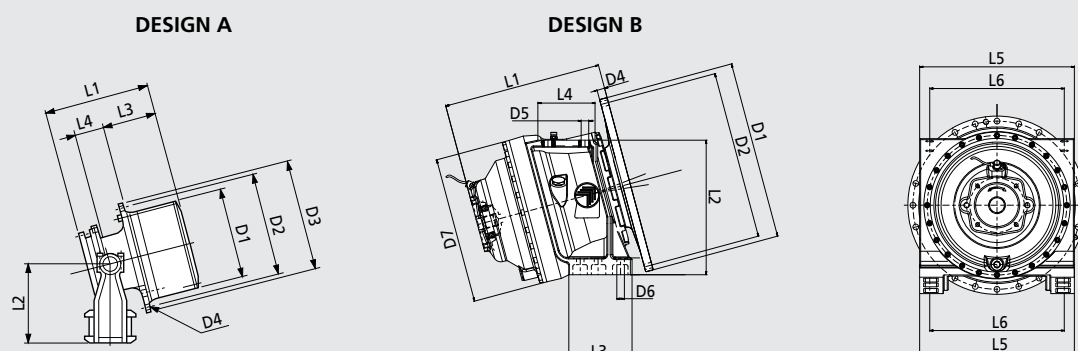

TYPE	D1	D2	D3	D4	D5	D6	D7	L1	L2	L3	L4	L5	L6
501	200	222	245	13 n°4	–	–	–	270	195	138	89	–	–
564	280	310	340	17 n°10	–	–	–	365	240	165	85	–	–
565	280	310	340	17 n°10	–	–	–	290	240	165	85	–	–
567	358	390	430	17 n°18	–	–	–	435	300	210	110	–	–
568	358	390	430	17 n°18	–	–	–	360	300	210	110	–	–
575	530	500	–	17 n°24	22 n°4	22 n°6	435	450	400	188	170	460	400
577	530	500	–	17 n°24	22 n°4	22 n°6	435	450	400	188	170	460	400
580	530	500	–	17 n°24	22 n°4	22 n°6	435	525	400	188	170	460	400

600 series Wheel drives

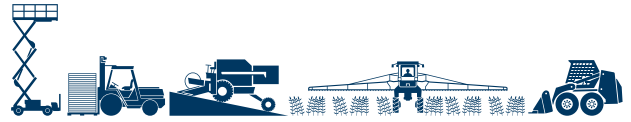

Benefit from the experience of the leading manufacturer.

Whether you are designing a wheeled agriculture or construction equipment, the 600 series will offer you the right choice for your vehicle.

A disengagement device to tow the vehicle in an emergency is optionally available.



Torque Range

3000 ... 85000 Nm

Gear Ratios

4.3 ... 153

Key Features

- Rotating housing flange with studs
- to fit wheels and drums
- Rugged design
- High torque capacity
- High load capacity
- Mechanical lifetime seals
- Compact design
- Optional mechanical gear disengagement on request

Applicable motors

- Cartridge axial piston hydraulic motors
- Flanged axial piston hydraulic motors
- Hydraulic orbit motors
- DC electric motors

Brake

Hydraulically released parking brake on request

Type	Torque (Nm)
601 R1L	3000
603 W2..H	5000
603 W2V B	7000
605 W2V..	10000
606 W..V	17000
607 W..V	22000
609 W..V	30000
610 W..V	36000
610 X	40000
611 W..V	45000
613 W..V	60000
615 W..V	85000



Overall dimensions and technical data

TYPE	RANGE OF RATIOS	MAX. INPUT SPEED	HYDRAULIC MOTOR DRIVE ⁽¹⁾	BRAKING TORQUE	MIN. OPENING PRESSURE	WEIGHT	DESIGN
	1:			Nm	bar	kg	
601 R1	4.26 - 5.77	1000	LS	450 - 600	15 - 20	35	A
603 W2V H	19.5 - 40.5	4000	HS	170 - 250	15 - 20	45	B
603 W2L H	14 - 40.5	4000	HS	170 - 250	15 - 20	45	A
603 W2V B	21.6 - 53	4000	HS	170 - 250	15 - 20	45	B
605 W2 H	22.2 - 53	3500	HS	220 - 310	15 - 20	65	B
605 W2 B	22.2 - 53	3500	HS	220 - 300	15 - 20	65	B
606 W2	19.7 - 43.8	3500	HS	400 - 500	15 - 20	110	B
606 W3	68 - 128.6	3500	HS	300 - 350	15 - 20	120	B
607 W..V	55-120	3000	HS	300 - 600	15 - 20	140	B
609 W..V	55-147	3000	HS	300 - 600	15 - 20	170	B
610 W..V	55-123	3000	HS	300 - 800	15 - 20	200	B
610 X2	22.5-51.4	3000	HS	800 - 1200	15 - 20	200	B
611 W..V	41-47	3000	HS	300 - 800	15 - 20	250	B
613 W..V	108	3000	HS	300 - 800	15 - 20	250	B
615 W..V	108	3000	HS	300 - 1000	15 - 20	350	B

(1) LS = Low speed motor / HS = High speed motor

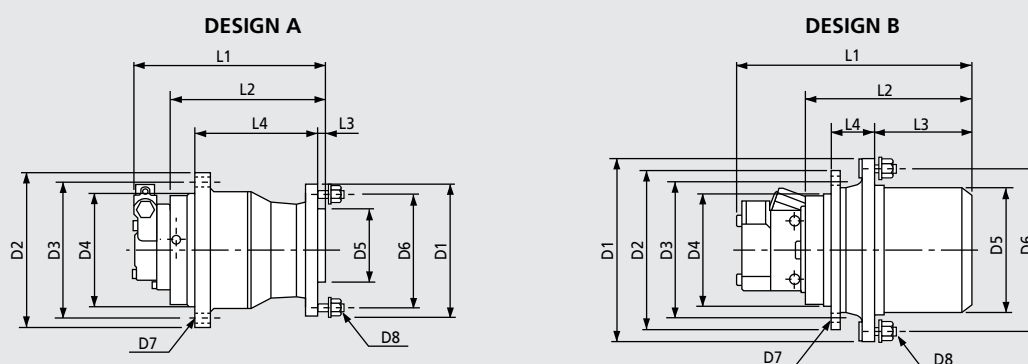

TYPE	D1	D2	D3	D4	D5	D6	D7	D8	L1	L2	L3	L4
601 R1L	230	260	230	200 h8	152,4	203,2	Ø15 n°8	M14x1.5 n°8	Depend on motor type	245	10	195
603 W2V H	280	270	230	190 f7	200 h8	241,3	M16x2 n°8	M18x1.5 n°9		236	128	72
603 W2L H	237	270	230	190 f7	160	205	M16x2 n°8	M18x1.5 n°6		249.5	25	175
603 W2V B	275	240	210	178 h8	200 h8	241,3	M16x2 n°9	M16x1.5 n°9		249	108	106
605 W2 H	300	270	230	190 f7	220 h8	260	M16x2 n°8	M16x1.5 n°8		240	154	72
605 W2 B	310	260	230	190 f7	220 h8	275	M16x2 n°12	M20x1.5 n°8		218	136	72
606 W2	370	330	300	270 h8	280 h8	335	M16x2 n°18	M22x1.5 n°10		270	155	115
606 W3	370	330	300	270 h8	280 h8	335	M16x2 n°18	M22x1.5 n°10		315	200	115
607 W..V	400	317	285	240	300	355	M20x2.5 n°20	M18x1.5 n°20		335	233	82
609 W..V	435	375	340	300	350	400	M20x2.5 n°16	M22x1.5 n°16		350	243	91
610 W..V	435	375	340	300	350	400	M20x2.5 n°16	M22x1.5 n°16		350	243	91
610 X2	440	410	370	330	360	400	M20x2.5 n°20	M20x2.5 n°16		383	268	90
611 W..V	490	425	325	290	410	455	M20x2.5 n°24	M20x1.5 n°24		375	242	110
613 W..V	490	425	325	280	410	455	M20x2.5 n°24	3/4-16 UNF n°24		405	275	110
615 W..V	550	500	460	420	460	510	M20x2.5 n°24	M20x1.5 n°24		470	320	130



600E series

Electric powertrains

Electric solutions for wheel drives.

Bonfiglioli's 600E planetary drives incorporate an integrated, maintenance-free electric motor and offer significant benefits in terms of compact dimensions, low noise and high efficiency. 600 Series drives are designed for use with all kinds of aerial platforms and other kinds of mobile machinery, for indoor and outdoor use. This advanced powertrain solution uses a two or three stage gearbox offering reduction ratios of up to 1:145 to satisfy the widest possible range of needs. The gearbox is coupled to a low voltage induction motor (BT Series) specially developed for traction power and control applications.



Torque Range

900 ... 10000 Nm

Gear Ratios

20 ... 145

Key standard features

- Two or three stage planetary drive with reduction ratios of up to 1:145
- Optimised gear design for maximum efficiency and minimum noise
- Integrated, low voltage, 3 phase induction motor with inverter
- Integrated, high accuracy, KTY temperature sensor
- Integrated, high resolution, Hall effect speed sensor

Optional features available on request

- Speed sensor-bearing
- Other types of temperature sensor
- Mechanical disengagement for towing, with no need to remove the wheel and without oil drop
- Parking brake (spring applied with hydraulic or electromagnetic release)

Type	Max deliverable torque (Nm)
600 WE	900
601 RE	3000
602 RE	3500
602 WE	4500
604 WE	7000
605 WE	10000



Overall dimensions and technical data

TYPE	RATIOS	MAX INPUT SPEED	WEIGHT	OIL QUANTITY	AC ELECTRIC MOTOR - SIZE				PARKING BRAKE		MACHINE TON CLASS
					BT135	BT150	BT170	BT200	Electromagnetic	Hydraulic	
	1:	rpm	kg	L							ton
600 WE	48- 58.7	6000	35	0.5	•	•			•		3
601 RE	20.1 - 51.8	4000	40	0.8		•	•		•	•	6
602 RE	20.3 - 30.6	6000	53	0.7		•	•		•	•	9
602 WE	20 - 145	6000	45	0.5		•	•		•	•	9
604 WE	22.2 -53	5000	65	1.1			•	•	•	•	13
605 WE	22.2 - 53	5000	65	1.1			•	•		•	16

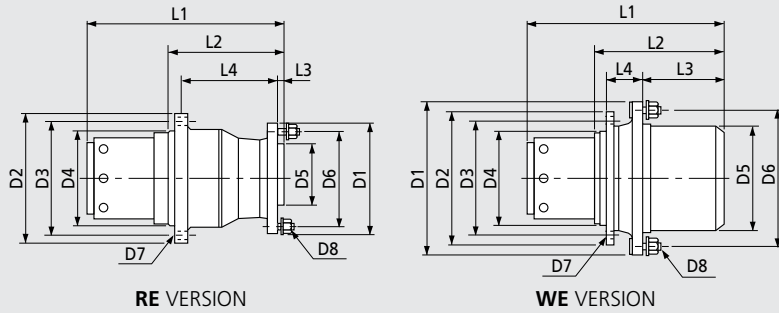

TYPE	BT 135-			BT 150-			BT 170-			BT 200-		
	50	100	150	50	100	150	50	100	150	50	100	150
P _n (S2 60') (kW)	0.9	1.6	2.3	1.5	2.5	3.4	2.4	4.3	5.4	3.1	6.2	9.1
T _n (Nm)	3	5.6	8.5	4.8	9.1	12.5	7.7	14	22	10	20	29.5
V _{batt} (V)	24	24	24	24	24	24	48	48	48	80	80	80
I _n (A)	55	95	128	80	130	175	67	110	143	53	98	137
n (rpm)	2930	2927	2632	2894	2617	2610	2945	2952	2357	2957	2963	2958
cosφ	0.77	0.8	0.81	0.85	0.86	0.87	0.77	0.83	0.8	0.77	0.8	0.84
η (%)	86.9	89.5	90.0	85.5	88.7	89.2	88.3	89.6	91.3	88.8	91.6	92.5

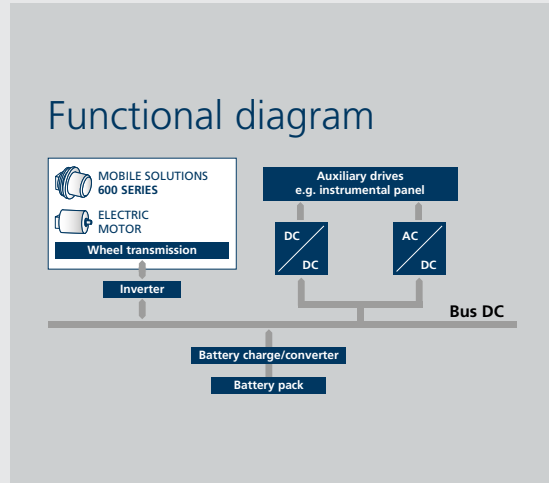

TYPE	L1								L2 L3 L4 D1 D2 D3 D4 D5 D6 D7 D8												
	275	325	375	290	340	390															
600 WE																					
601 RE					453	503	412	462													
602 RE						524	434	484	534												
602 WE						455	375	425	475												
604 WE								464	514	446	496										
605 WE								524	456	506	556										

TYPE	MACHINE WEIGHT (TON)																
	0.5	1	2	3	4	5	6	7	8	9	10	11	12	13	14	15	16
600 WE	0.9 ... 2 kW																
601 RE			1.5 ... 3 kW														
602 RE					3 ... 4 kW												
602 WE					2 ... 4.5 kW												
604 WE									4.5 ... 6 kW								
605 WE														6 ... 9 kW			

Vertical booms																	
Height (m)	5	6.5	8	10													
Scissors lift																	
Height (m)	6.5	7.5	10	11.5	12.5	14	15	18									
Telescopic / Articulated booms																	
Height (m)						11	12	14	15	16	17.5	19	20	21	25	26	27

PGW series Wheel drives



Benefit from the experience of the leading manufacturer.

Whether you are designing a wheeled agriculture or construction equipment, the PGW series will offer you the right choice for your vehicle.

A disengagement device to tow the vehicle in an emergency is optionally available.



Torque Range

1300 ... 4000 Nm

Gear Ratios

3.3 ... 57.5

Key Features

- Rotating housing flange with studs to fit wheels and drums
- Rugged design
- High torque capacity
- High load capacity
- Mechanical lifetime seals
- Compact design
- Optional mechanical gear disengagement on request

Applicable motors

- Cartridge axial piston hydraulic motors
- Flanged axial piston hydraulic motors
- Hydraulic orbit motors

Brake

Hydraulically released parking brake on request

Type	Torque [Nm]
PGW 130	1300
PGW 220	2200
PGW 401	3500
PGW 402	4000



Overall dimensions and technical data

TYPE	MAX. TORQUE	RATIOS	MAX. INPUT SPEED	HYDRAULIC MOTOR DRIVE ⁽¹⁾	BRAKING TORQUE	MIN. OPENING PRESSURE	WEIGHT	DESIGN
	Nm	1:	min ⁻¹		Nm	bar	kg	
PGW-PGWF 130	1300	3.28 - 4.6 - 5.75	1500	LS	420 - 750	25 - 30	21	A
PGW-PGWF 220	2200	5.75	1500	LS	750	25	35	A
PGW-PGWF 401	3500	5.6	1500	LS	500	17	35	A
PGW-PGWF 402	4000	14.0 - 57.5	3500	HS	330	15	38	B

(1) **LS** = Low speed motor / **HS** = High speed motor

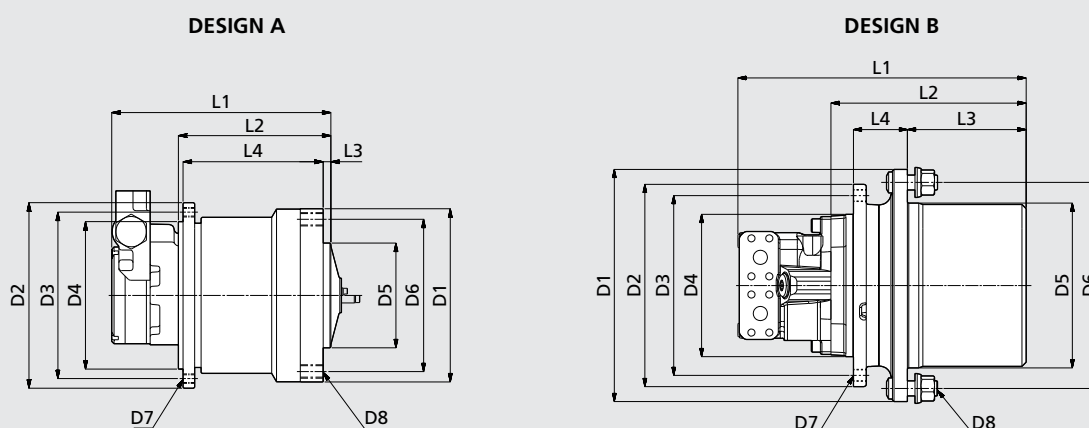

TYPE	D1	D2	D3	D4	D5	D6	D7	D8	L1	L2	L3	L4
PGW-PGWF 130	182	195	175	155	110	160	M10x1.5 n°8	M14x1.5 n°5	Depend on motor type	167	8	147
PGW-PGWF 220	182	215	185	160	110	160	M14x1.75 n°12	M14x1.5 n°5		210	8	170
PGW-PGWF 401	230	260	230	200	152.4	203.2	Ø15 n°8	M14x1.5 n°8		250	15	175
PGW-PGWF 402	280	270	230	190	200	245	M16x2 n°8	M16x1.5 n°6		210	120	72

600W2/3 series Wheel drives



Gear shift final drive LO-HI Speed.

This gear shift final drive is specifically designed for wheeled and tracked machines featuring a significantly different travel/operating speed ratio.

The product is the ideal solution for road paving machines, construction equipment, as well as agricultural and forestry machines.

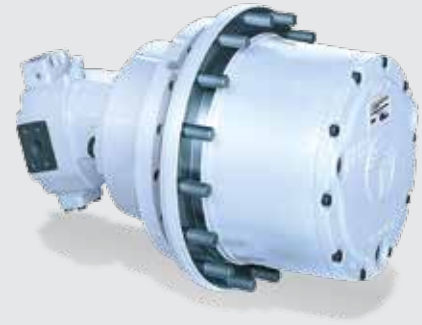

Torque Range

15000 ... 50000 Nm

Gear Ratios

LO speed: 71 87 85 104 141,3

HI speed: 20.5 20.5 24.5 24.5 24.5

Key Features

- Dual gear ratio, hydraulic Lo-Hi speed shifting
- Rotating housing
- Rugged design
- High torque capacity
- High load capacity
- Mechanical lifetime seals
- Compact design
- Hydraulically operated multidisc clutches, allowing both speed shifting and brake

Applicable motors

Cartridge axial piston hydraulic motors

Brake

- Hydraulically released multidisc type
- Parking braking
- Emergency braking

Type

Torque [Nm]

Type	Torque [Nm]
606W2/3	15000
610W2/3	40000
611W2/3	50000



Overall dimensions and technical data

TYPE	MAX. INPUT SPEED	MAX. OUTPUT SPEED	DYNAMIC & EMERGENCY BRAKING TORQUE	BRAKING TORQUE	BRAKE & CLUTCH RELEASE PRESSURE	WEIGHT	OIL QUANTITY
	rpm	rpm	Nm	Nm	bar	kg	L
606W2/3	3500	140	20000	400	20 ÷ 40	180	2.5
610W2/3	3000	120	30000	550	20 ÷ 40	200	3
611W2/3	3000	100	55000	600	20 ÷ 40	270	5

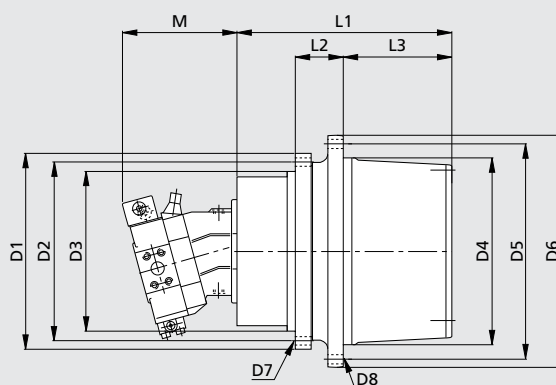

TYPE	D1	D2	D3	D4	D5	D6	D7	D8	L1	L2	L3
606W2/3	430	360	300	290	335	370	M16x2 n°16	M22x1.5 n°10	305	188	135
610W2/3	375	340	300	350	400	435	M20x2.5 n°16	M20x2.5 n°16	388	91	203
611W2/3	570	525	465	410	455	488	ø22 n°12	M22x1.5 n°20	366	113	219

700C series Travel drives

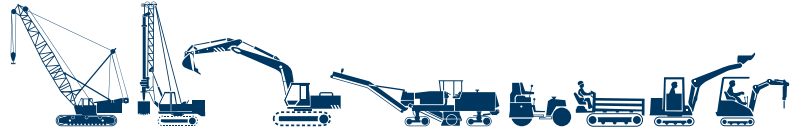

Leadership is never achieved without continuing efforts and consistent product development.

Any crawler machine, no matter how big or small, will find the suitable travel drive within the range of the 700C series.

All units available with a failsafe parking brake and for most cartridge type fixed or variable displacement hydraulic motors.



Torque Range

1000 ... 625000 Nm

Gear Ratios

5.3 ... 492

Key Features

- Rotating housing
- Rugged design
- High torque capacity
- High load capacity
- Mechanical lifetime seals
- Compact design

Applicable hydraulic motors

- Cartridge axial piston motors
- Flanged axial piston motors
- Orbit motors

Brake

Hydraulically released parking brake on request

Type	Torque (Nm)
700 C1 H	1000
701 C1	2200
703 C2 H	4000
705 C2 H	10000
706 C3 B	18000
707 C3 B	26000
709 C3 B	30000
710 C3 B	36000
711 C3 B	45000
713 C3 B	60000
715 C3 B	85000
716 C3 B	100000
717 C3 H	130000
718 C3 H	180000
720 C3 H	220000
722 C3 H	330000
724 C4 H	450000
726 C4 H	625000



Overall dimensions and technical data

TYPE	RANGE OF RATIOS	MAX. INPUT SPEED	HYDRAULIC MOTOR DRIVE	BRAKING TORQUE	MIN. OPENING PRESSURE	WEIGHT
	1:	RPM	Inline	Right angle		
700 C1 H	5.25	1000	LS	140 - 250	15 - 25	20
701 C1	6.2	1000	LS	250 - 350	20 - 30	25
703 C2 H	19-40	3500	HS	210	18	42
705 C2 H	22-53	3500	HS	220 - 310	10 - 20	60
706 C3 B	68-173	3500	HS	250 - 500	10 - 20	95
707 C3 B	55-120	3500	HS	250 - 500	10 - 20	135
709 C3 B	55-147	3500	HS	250 - 600	10 - 20	180
710 C3 B	55-166	3500	HS	250 - 600	10 - 20	200
711 C3 B	71-163	3500	HS	400 - 800	10 - 20	270
713 C3 B	56-147	3000	HS	400 - 800	10 - 20	310
715 C3 B	62-156	3000	HS	600 - 1000	10 - 20	350
716 C3 B	83-174	3000	HS	800 - 1200	10 - 20	400
717 C3 H	92-211	3000	HS	800 - 1200	10 - 20	630
718 C3 H	87-263	3000	HS	800 - 1400	10 - 20	750
720 C3 H	175-287	3000	HS	800 - 1700	10 - 20	820
722 C3 H	296-492	3000	HS	1500 - 2500	15 - 30	1300
724 C4 H	350 - 428	3000	HS	1500 - 2500	15 - 30	1300
726 C4 H	248-282-330	3000	HS	2 x 1200	27	2800

(1) **LS** = Low speed motor / **HS** = High speed motor

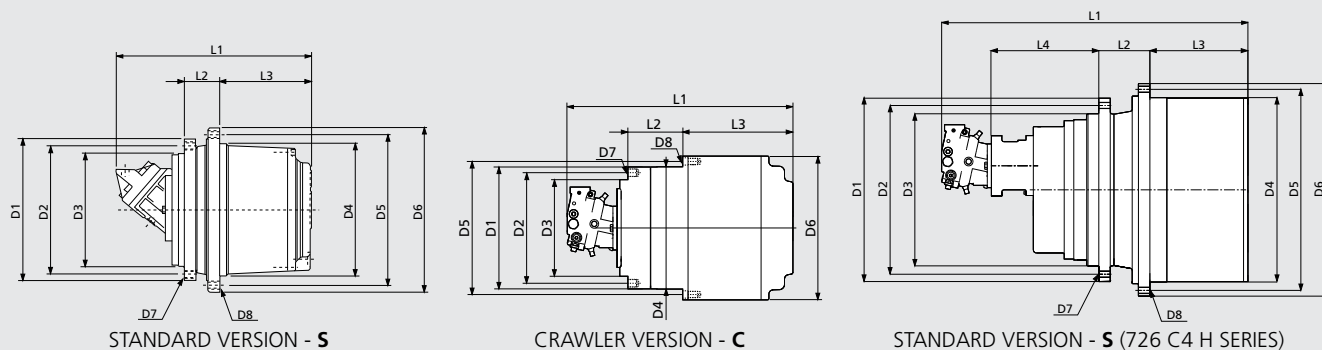

TYPE	D1	D2	D3	D4	D5	D6	D7	D8	L1	L2	L3	L4	VERSION
700 C1 H	195	175	155	160	180	200	M10x1.5 n°8	M10x1.5 n°8	Depend on motor type	40	80	-	S
701 C1	230	200	180	190	210	230	M10x1.5 n°8	M10x1.5 n°8		40	105	-	S
703 C2 H	270	230	190	200	240	280	M16x2 n°8	M20x1.5 n°8		72	128	-	S
705 C2 H	270	230	190	220	260	300	M16x2 n°12	M16x2 n°16		72	158	-	S
706 C3 B	330	300	270	280	330	370	M16x2 n°18	M16x2 n°18		115	190	-	S
707 C3 B	317	285	240	300	340	370	M20x2.5 n°20	M16x2 n°20		82	233	-	S
709 C3 B	375	340	300	330	370	400	M20x2.5 n°16	M16x2 n°30		91	243	-	S
710 C3 B	375	340	300	350	400	435	M20x2.5 n°16	M20x2.5 n°16		91	243	-	S
711 C3 B	425	325	290	410	455	490	M20x2.5 n°24	M20x2.5 n°24		110	265	-	S
713 C3 B	425	325	290	410	455	490	M20x2.5 n°24	M20x2.5 n°24		110	280	-	S
715 C3 B	500	460	420	460	510	550	M20x2.5 n°24	M20x2.5 n°24		130	315	-	S
716 C3 B	500	460	420	460	500	550	M24x3 n°24	M18x1.5 n°36		165	308	-	S
717 C3 H	570	510	450	560	610	660	M30x3.5 n°20	M24x3 n°24		170	350	-	S
718 C3 H	570	510	450	576	626	670	M24x3 n°30	M24x3 n°20		170	350	-	S
720 C3 H	650	600	460	610	680	735	M30x3.5 n°30	M30x3.5 n°24		170	370	-	S; C
722 C3 H	735	680	580	660	730	785	M30x3.5 n°30	M30x3.5 n°30		188	430	-	S
724 C4 H	568	515	450	570	620	670	M36x1.5 n°29	M30x1.5 n°42		255	513	-	S; C
726 C4 H	880	810	730	885	965	1020	M30x2 n°41	M30x2 n°48		245	470	515	S; C

700CK series

Track drive gearmotors



Integrated design will result into the best possible product combination.

Extreme compactness, lightweight, efficiency and smooth operation are the key features of the 700CK series track drives, powered by integrated axial piston hydraulic motors, developed in cooperation with KAYABA.

Available for machines in the 1.5 to 100 Ton class range.



Torque Range

1200 ... 220000 Nm

Machine weight

1.5 up 100 Ton

Gear Ratios

20 ... 120

Key Features

- Rotating output flange with large PCD suitable for sprocket
- Rugged design
- High torque capacity
- High load capacity
- Mechanical lifetime seals
- Compact design

Hydraulic motors

KAYABA hydraulic motors, fixed and dual displacement, complete with counterbalance valve.

Motor options

Pressure relief valves, shockless type
Anticavitation valve

Brake

Hydraulically released failsafe parking brake automatically operated by main pressure

Type	Torque (Nm)
700 C2 K	1200
700-2C2 K	1900
701 C2 K	2500
702 C2 K	3500
704 C2 K	5000
705 C2 K	9000
706 C3 K	18000
707 C3 K	26000
709 C3 K	30000
710 C3 K	36000
713 C2 K	45000
713 C3 K	60000
715 C3 K	85000
716 C3 K	100000
718 C3 K	180000
720 C3 K	220000



Overall dimensions and technical data

TYPE	MOTOR DISPLACEMENT	MAX. PRESSURE	MAX. FLOW	2 SPEED CONTROL MIN. PRESSURE	PARKING BRAKE TORQUE	RANGE OF RATIOS	WEIGHT	APPROX. WEIGHT OF MACHINE
	max/min	bar	l/min	bar	Nm	1:	Kg	ton
700 C2 K	12-5.5	210	20	6	25	32-41	20	1.6
700-2C2 K	18-9	210	30	6	25	30-42	25	2
701 C2 K	18-11.6	250	35	6	25	30-53	25	3
702 C2 K	26.3-13.4	250	45	6	40	37-53	35	4
704 C2 K	33.8-19	250	60	6	40	45-53	60	5.5
705 C2 K	50.9-25.4	320	92	6	50	24-53	70	7
706 C3 K	50-25	300	75	6	50	68-128	80	8-10
707 C3 K	87-50	300	120	10	240	46-109	140	10-12
709 C3 K	87-50	300	160	10	400	53-123	225	13-20
710 C3 K	170-96	300	240	10	400	49-69	230	20-25
713 C2 K	170-96	300	230	10	400	55	280	25-29
713 C3 K	230-120	345	310	10	400	60-75	300	29-37
715 C3 K	230-340	345	370	10	400	62-82	380	37-50
716 C3 K	340	345	420	10	2000	75	500	50-60
718 C3 K	340	345	500	10	2000	85-106	850	60-80
720 C3 K	340	345	500	10	2000	120	1000	up to 120

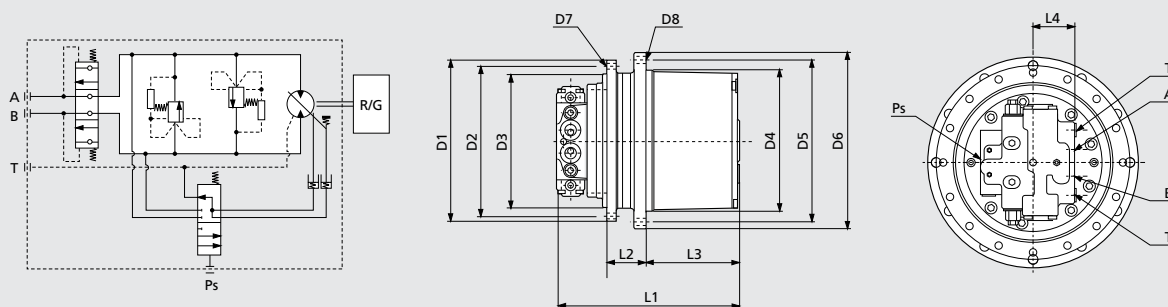

TYPE	D1	D2	D3	D4	D5	D6	D7	D8	L1	L2	L3	L4	A-B	T	PS
700 C2 K	175	155	140	140	155	175	M10x1.5 n°8	M10x1.5 n°8	202	45	93	40	1/4"	1/4"	1/4"
700-2C2 K	190	170	150	160	180	200	M10x1.5 n°8	M10x1.5 n°8	223	40	108	39	3/8"	1/4"	1/4"
701 C2 K	215	192	165	190	215	240	M12x1.75 n°9	M12x1.75 n°9	300	50	125	45	1/2"	1/4"	1/4"
702 C2 K	215	192	165	204	232	255	M12x1.75 n°9	M12x1.75 n°9	285	70	115	45	1/2"	1/4"	1/4"
704 C2 K	264	240	200	230	262	286	M14x2 n°9	M14x2 n°9	345	68	167	46	1/2"	3/8"	1/4"
705 C2 K	268	244	210	230	260	286	M14x2 n°12	M14x2 n°12	340	75	144	50	1/2"	3/8"	1/4"
706 C3 K	308	280	246	280	330	370	M16x2 n°20	M16x2 n°12	412	100	193	50	1/2"	3/8"	1/4"
707 C3 K	350	320	280	300	340	370	M16x2 n°16	M16x2 n°20	440	91	210	84	3/4"	1/2"	1/4"
709 C3 K	375	340	300	330	370	400	M16x2 n°30	M16x2 n°30	470	99,5	246	84	3/4"	1/2"	1/4"
710 C3 K	375	340	300	350	400	435	M16x2 n°30	M16x2 n°30	455	91	243	84	3/4"	1/2"	1/4"
713 C2 K	450	410	360	410	455	490	M24x3 n°18	M20x2.5 n°22	500	106	265	84	3/4"	1/2"	1/4"
713 C3 K	480	440	380	410	455	490	M24x3 n°18	M20x2.5 n°24	570	100	287	90	1"	1/2"	1/4"
715 C3 K	500	460	420	460	510	550	M20x2.5 n°24	M20x2.5 n°24	605	130	315	90	1"	1/2"	1/4"
716 C3 K	500	460	420	460	500	548	M24x3 n°24	M18x1.5 n°36	663	165	308	118	1"	3/4"	1/4"
718 C3 K	570	510	450	576	626	670	M24x3 n°30	M24x3 n°30	730	170	350	118	1"	3/4"	1/4"
720 C3 K	650	600	480	610	680	735	M30x3.5 n°30	M24x3.5 n°24	800	170	370	118	1"	3/4"	1/4"

PGR series

Track drive gearmotors



Integrated design will result into the best possible product combination.

Extreme compactness, lightweight, efficiency and smooth operation are the key features of the PGR series track drives, powered by integrated axial piston hydraulic motors.

Available for machines in the 1.3 to 7 Ton class range.



Torque Range

1000 ... 7000 Nm

Machine weight

1.3 up 7 Ton

Gear Ratios

3.3 ... 57.5

Key Features

- Rotating output flange with large PCD suitable for sprocket
- Rugged design
- High torque capacity
- High load capacity
- Mechanical lifetime seals
- Compact design

Hydraulic motors

Fixed and dual displacement, complete with counterbalance valve.

Motor options

Pressure relief valves, shockless type
Anticavitation valve

Brake

Hydraulically released failsafe parking brake automatically operated by main pressure

Type	Torque (Nm)
PGR 92	1000
PGR 130	1300
PGR 132	1300
PGR 280	2800
PGR 302	3000
PGR 402	4000
PGR 602	7000



Overall dimensions and technical data

TYPE	MOTOR DISPLACEMENT	HYDRAULIC MOTOR DRIVE ⁽¹⁾	MAX. PRESSURE	MAX. FLOW	2 SPEED CONTROL MIN. PRESSURE	PARKING BRAKE TORQUE	RATIOS	WEIGHT	APPROX. WEIGHT OF MACHINE
	Max/Min		bar	l/min	bar	Nm	1:	kg	ton
PGR-PGRF 130	50 up to 250	LS	140	25	6	25	3.28 - 4.26 - 5.75	22	1.8
PGR-PGRF 280	50 up to 315	LS	140	25	6	25	6.09	40	3
PGR-PGRF 92	17.85 - 8.7	HS	210	20	6	25	18.5 - 26.5	18	1.3
PGR-PGRF 132	17.85 - 8.7	HS	210	35	6	40	18.9 - 36.8	24	1.8
PGR-PGRF 302	17.85 - 8.7	HS	210	35	6	40	31.1 - 57.5	36	3.5
PGR-PGRF 402	29.0 - 11.8	HS	210	50	6	50	31.1 - 57.5	41	4.5
PGR-PGRF 602	36.4 - 16.7	HS	210	65	10	50	30 - 55	60	7

(1) **LS** = Low speed motor / **HS** = High speed motor

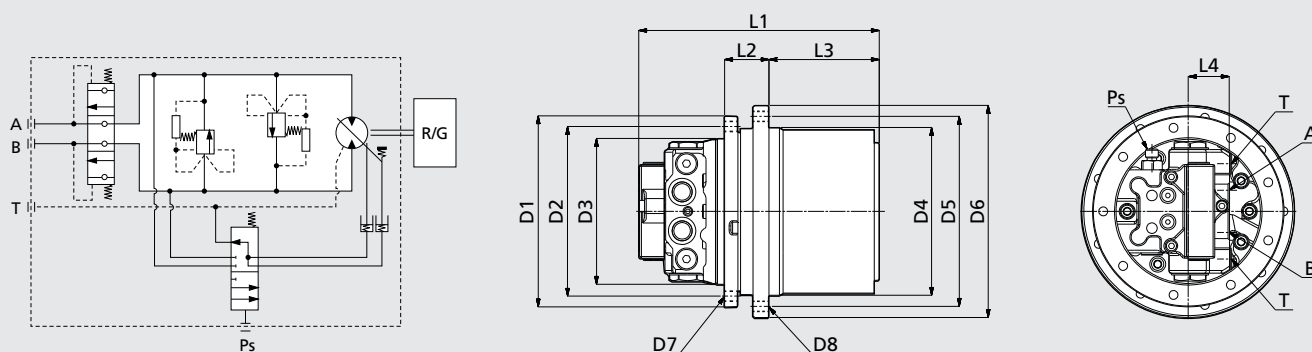

TYPE	D1	D2	D3	D4	D5	D6	D7	D8	L1	L2	L3	L4	A-B	T	Ps
PGR-PGRF 130	190	170	150	160	180	200	M10x1.5 n°8	M10x1.5 n°9	*	40	92	*	*	*	*
PGR-PGRF 280	230	200	180	190	210	230	M10x1.5 n°8	M10x1.5 n°8	*	40	115	*	*	*	*
PGR-PGRF 92	175	155	140	140	155	175	M10x1.5 n°8	M10x1.5 n°9	220	45	138	*	*	*	*
PGR-PGRF 132	195	175	155	160	180	200	M10x1.5 n°8	M10x1.5 n°8	250	40	108	*	*	*	*
PGR-PGRF 302 M	215	192	165	204	232	255	M12x1.75 n°9	M12x1.75 n°9	277	66	119	*	*	*	*
PGR-PGRF 302 K	215	192	165	190	215	239	M12x1.75 n°9	M12x1.75 n°9	277	50	119	*	*	*	*
PGR-PGRF 402	215	192	165	204	232	255	M12x1.75 n°9	M12x1.75 n°9	304	70	119	*	*	*	*
PGR-PGRF 602	264	240	200	230	262	286	M14x1.75 n°12	M14x1.75 n°12	335	68	139	*	*	*	*

* Depend on motor version

700CT series

Track drive gearmotors

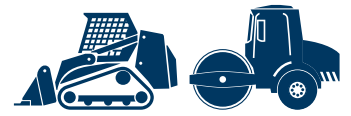

Integrated design will result into the best possible product combination.

Extreme compactness, lightweight, efficiency and smooth operation are the key features of the 700CT series track drives, powered by integrated axial piston hydraulic motors.

Available for machines in the 2.5 to 9 Ton class range.



Torque Range

3500 ... 12500 Nm

Machine weight

2.5 up 9 Ton

Gear Ratios

15 ... 53

Key Features

- Rotating output flange with large PCD suitable for sprocket
- Rugged design
- High torque capacity
- High load capacity
- Mechanical lifetime seals
- Compact design

Hydraulic motors

Bonfiglioli Trasmital hydraulic motors, fixed OR dual displacement, with flushing valve circuit, suitable for closed loop applications.

Motor options

Speed sensor mounting.

Brake

Hydraulically released spring applied parking brake, with external independent port.

Type	Torque (Nm)
702 C2 T	3500
704 C2 T	5000
705 C2 T	9000
706 C2 T	12500



Overall dimensions and technical data

TYPE	WEIGHT	OUTPUT TORQUE	RATIOS	MOTOR TYPE
	tons	Nm	1:	
702 C2 T	2.5 - 3.5	3500	15 ÷ 22	high speed
704 C2 T	3.5 - 5	5000	18	high speed
705 C2 T	5 - 7	9000	25 ÷ 30	high speed
706 C2 T	7 - 9	12500	53	high speed

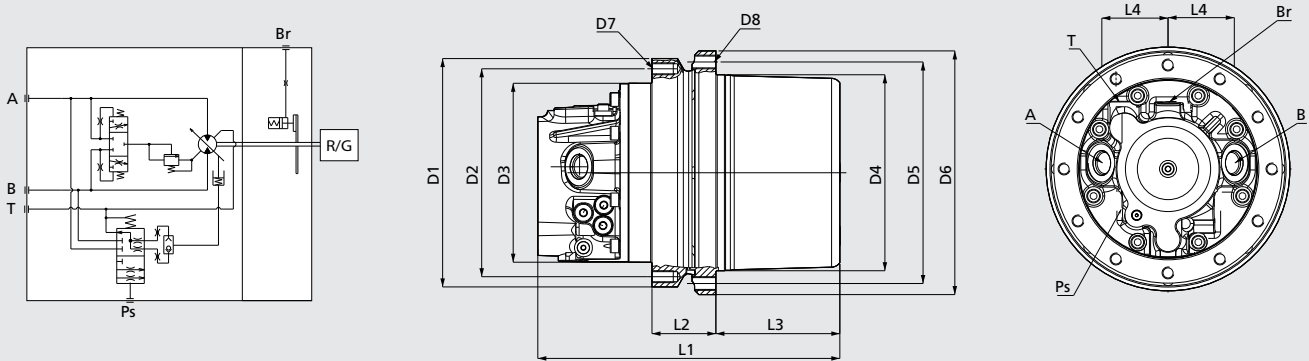

TYPE	D1	D2	D3	D4	D5	D6	D7	D8	L1	L2	L3	L4	A-B	T	PS
702 C2 T	270	240	210	210	245	275	M16x2 n°8	M16x2 n°12	340	153	70	77	1" 1/16-12 UNF	3/4"-16 UNF	9/16"-18 UNF
704 C2 T	268	244	210	230	260	286	M14x2 n°12	M16x2 n°8	355	75	146	77			
705 C2 T	268	244	210	230	260	286	M14x2 n°12	M14x2 n°12	355	75	144	77			
706 C2 T	308	280	246	275	305	331	M14x2 n°16	M14x2 n°16	390	100	156	77			

700C series

Drum drives for milling machine

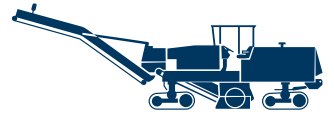

Dual stage planetary drive units with integrated pulley support designed for Cold Planers and Milling Machines from 15 to 35 ton with engine power from 200 to 420kW and Rotor width from 4 to 6 m/s.

The offset input option ensures higher machine productivity due to the increased cutting depth.

The unique integrated cooling system allow greater performances, easier system maintenance and the highest level of reliability.



Cold Planers and Milling machine with the following features:

- Machine weight from 15 to 35 tons
- Engine power from 220 to 420 kW
- Rotor width from 1.0 to 2.5 m
- Rotor tip speed from 4 to 6 m/s

Planetary gearbox specifically designed for drum drive:

- Dual stage planetary reduction
- Integrated pulley support shaft with reinforced bearings
- Optimized housing design for improved lubrication performance
- Offset input available for increased cutting depth
- Integrated cooling system (optional)

Type	Torque (Nm)
713 C2 H	25000
716 C2 H	45000



Overall dimensions and technical data

TYPE	RATIOS	MAX CUTTING TORQUE	MAX INPUT POWER	BEARINGS LOAD RATINGS		VERSION
				C dyn. (kN)	C0 stat. (kN)	
	1:	Nm	kW			
713 C2 H	16.4 - 19 - 22.9	25000	220	473	950	Offset
716 C2 H	18.5 - 21.8	45000	380	484	1000	In line

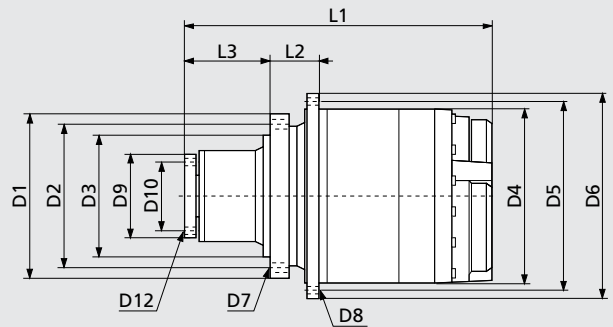
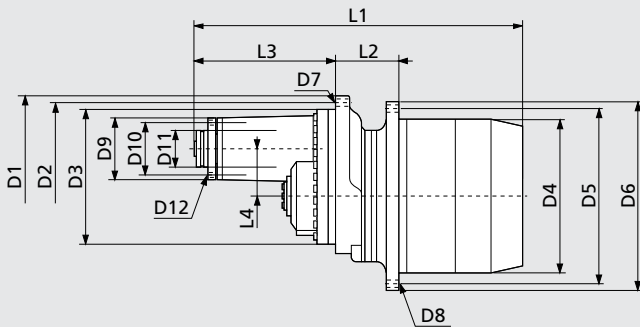

TYPE	VERS.	D1	D2	D3	D4	D5	D6	D7	D8	D9	D10	D11	D12	L1	L2	L3	L4
713 C2 H	Offset	420	385	350	400	450	490	M20x2.5 n°23	Ø22 n°23	160	130	95	M12x1.75 n°8	834	160	325	120
716 C2 H	In line	435	381	323.85	460	500	540	M20x2.5 n°23	Ø22 n°24	240	160	-	M16x2 n°6	799	125	224.5	-

700T series Slew drives



Innovative solutions for slew drives.

The slew drives of the 700T series provide the safest and most effective solution to all slew drive applications.

The 700T units have long been established in the cranes, excavators and special equipment industries, and today are highly appreciated by all the major manufacturers.



Torque Range

1000 ... 80000 Nm

Gear Ratios

3.4 ... 2000

Key Features

- Flange mounted
- Output shaft: splined or with integral pinion
- Rugged construction
- High torque capacity
- Output shafts supported by heavy duty capacity bearings

Hydraulic motor options

- Pressure relief valve
- Overcenter valve

Hydraulic Brake

- Hydraulically released parking brake on request

Electric Brake

- DC and AC type

Type	(Nm)
700 T1	1000
	1200
701 T1	1800
	2400
703 T2	2500
	3500
704 T2	3600
	4800
705 T2	5000
	6500
706 T2	7500
	10000
707 T2	9000
	15000
709 T2	12000
	20000
710 T2	18000
	30000
711 T2	20000
	35000
712 T3	30000
	45000
713 T3	40000
	55000
714 T3	50000
	65000
715 T3	70000
	80000

■ Excavator Torque
■ Crane Torque



Overall dimensions and technical data

TYPE	RANGE OF RATIOS	MAX. INPUT SPEED	HYDRAULIC MOTOR DRIVE ⁽¹⁾	BRAKING TORQUE	MIN. OPENING PRESSURE	WEIGHT	DESIGN
	max/min	bar		Nm	bar	Kg	
700 T1 F	3.48-7.2	500	LS	50 - 400	10 - 30	22	A
701 T1 F	3.48-7.2	500	LS	50 - 400	10 - 30	27	A
703 T2 F	12-44	3000	HS	50 - 400	10 - 30	45	A
704 T2 F	12-44	3000	HS	50 - 400	10 - 30	50	A
705 T2 F	12-44	3000	HS	50 - 400	10 - 30	55	A
705 T2 L	12-44	3000	HS	50 - 400	10 - 30	80	B
706 T2 N	15-46	3000	HS	400 - 1000	20 - 30	95	B
707 T2 N	17-47	3000	HS	400 - 1000	20 - 30	140	B
709 T2 N	17-47	3000	HS	400 - 1000	20 - 30	165	B
710 T2 N	19-38	3000	HS	400 - 1000	20 - 30	250	B
711 T2 C	14-39	3000	HS	400 - 1000	20 - 30	300	B
711 T2 F	14-39	3000	HS	400 - 1000	20 - 30	160	A
712 T3 F	80-200	3000	HS	400 - 1000	20 - 30	450	A
712 T3 N	80-200	3000	HS	400 - 1000	20 - 30	450	B
713 T3 N	50-300	3000	HS	400 - 1000	20 - 30	500	B
714 T3 F	90-180	3000	HS	400 - 1000	20 - 30	160	A
715 T3 N	57-250	3000	HS	400 - 1000	20 - 30	650	B

(1) LS = Low speed motor / HS = High speed motor

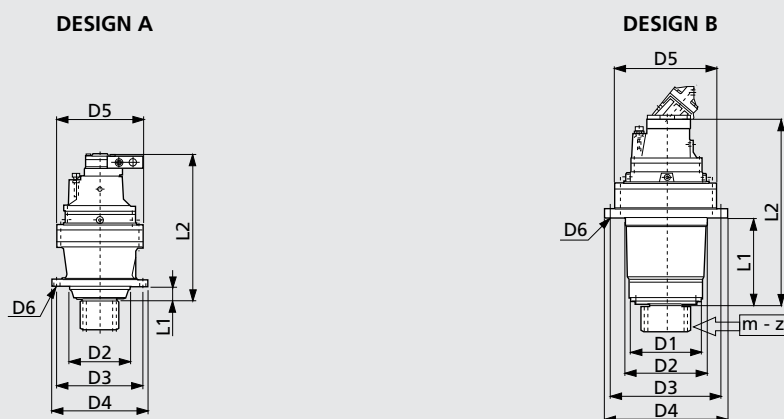

TYPE	D1	D2	D3	D4	D5	D6	L1	L2	m	z
700 T1 F	-	150	195	220	186	12.5	31	300		
701 T1 F	-	150	195	220	186	12.5	31	325		
703 T2 F	-	175	245	272	245	18	41	410		
704 T2 F	-	175	245	272	245	18	41	400		
705 T2 F	-	175	245	272	245	18	41	440		
705 T2 L	180	195	245	290	245	13	171	470		
706 T2 N	200	250	325	360	292	17	225	560		
707 T2 N	230	280	314	348	345	17	295	670		
709 T2 N	250	280	380	420	345	17	295	720		
710 T2 N	300	425	460	500	400	22	360	730		
711 T2 C	300	425	460	500	428	22	345	735		
711 T2 F	500	320	500	560	425	22	70	750		
712 T3 F	-	410	450	490	420	ø21 n°24	120	900		
712 T3 N	400	425	470	510	420	ø20 n°30	350	900		
713 T3 N	340	400	510	560	445	22	420	1030		
714 T3 F	-	420	490	530	490	ø22 n°24	160	1100		
715 T3 N	370	470	600	640	542	22	465	1250		

Module / number of teeth of pinion UPON REQUEST

700TK series

Slew drives



Slew drives for excavator duty.

The 700TK series is the compact and yet powerful package for the slew drive of excavators up to approx. 120 ton class.

The units are powered by integrated axial piston hydraulic motors, developed in cooperation with KAYABA and can be accommodated within the smallest space.

Wide choice of drive pinions, standard or to customer specs.



Torque Range

750 ... 30000 Nm

Excavator weight

1.5 to 120 Ton

Gear Ratios

7 ... 40

Key Features

- Flange mounted
- Output shaft with integral pinion
- Rugged construction
- High torque capacity
- Output shafts supported by heavy duty bearings
- Compact design

Hydraulic motors

KAYABA hydraulic motor fixed displacement complete with shockless type pressure relief valve

Motor options

Anti swing-back valve

Brake

- Hydraulically released failsafe parking brake
- Brake retarder valve on request

Type	Excavator Torque (Nm)
700 T1 K	750
701 T2 K	1200
703 T2 K	2500
705 T2 K	5000
706 T2 K	7500
707 T2 F	9000
709 T2 F	11000
710 T2 F	15000
711 T2 F	24000
713 T2 F	30000



Overall dimensions and technical data

TYPE	GEARBOX	MOTOR DISPLACEMENT	MAX. PRESSURE	MAX. FLOW	PARKING BRAKE		RANGE OF RATIO	APPROX. WEIGHT OF MACHINE
	nbr	cm	bar	l/min	Yes	No	1:	Ton
700 T1 K	1	27.4	210	18	•	•	8.2	1.5 - 2.5
701 T2 K	1	27.4	210	30	•	•	13.7-20.8	3 - 4
703 T2 K	1	27.4	250	50	•	•	14.8-35.6	5 - 6
705 T2 K	1	44.1	280	80	•		18-26.3	7 - 8
706 T2 K	1	87.3	320	160	•		15.3-33	9 - 13
707 T2 F	1	87.3	320	160	•		14.7-22.3	15 - 18
709 T2 F	1	130-160-180	270 ÷ 290	180 ÷ 240	•		19-25	21 - 26
710 T2 F	1	160-180	270 ÷ 290	250	•		22-26	26 - 30
711 T2 F	1	210	270 ÷ 290	290	•		21-25	30 - 35
709 T2 F	2	130-160-180	270 ÷ 290	180 ÷ 240	•		19-25	35 - 45
710 T2 F	2	160-180	270 ÷ 290	250	•		22-26	45 - 60
711 T2 F	2	210	270 ÷ 290	290	•		21-25	60 - 80
713 T2 F	2	160-180	270 ÷ 290	270	•		25-35	80 - 120

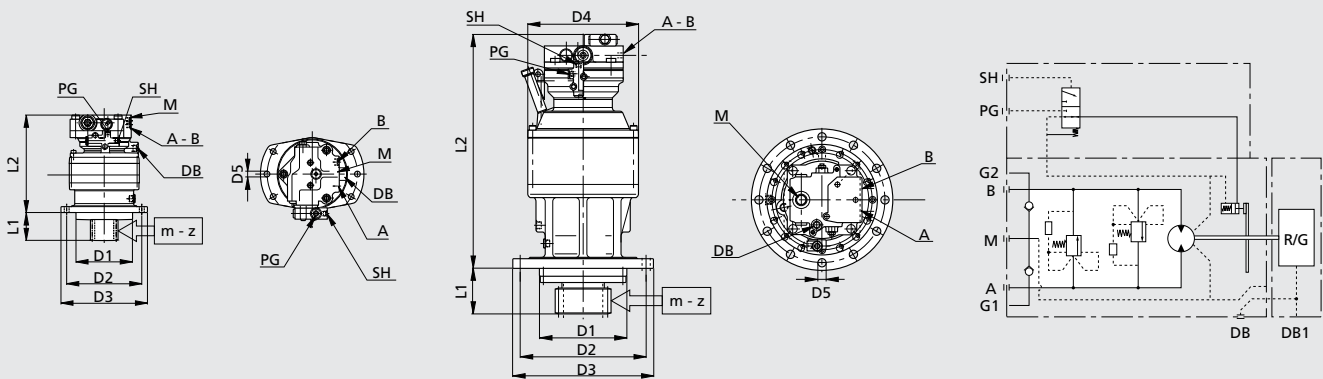

TYPE	D1	D2	D3	D4	D5	D6	A-B	DB	M	SH	PG	m	z
700 T1 K	-	228	260	186	∅ 13 n°6	76	MAIN PORT	DRAIN PORT	ANTICAVITATION PORT	SPOOL OPERATING PORT	BRAKE RELEASE PORT	Module / number of teeth of pinion UPON REQUEST	
701 T2 K	175	228	260	186	∅ 13 n°6	86							
703 T2 K	175	245	272	244	∅ 18 n°10	120							
705 T2 K	230	245	272	244	∅ 18 n°10	120							
706 T2 K	230	332	372	292	∅ 22 n°10	150							
706 T2 K	270	332	372	292	∅ 22 n°10	150							
707 T2 K	-	360	410	348	∅ 22 n°12	160							
707 T2 F	-	360	410	348	∅ 22 n°12	160							
709 T2 F	270	360	410	348	∅ 22 n°12	160							
710 T2 F	390	460	510	400	∅ 22 n°12	160							
711 T2 F	370	470	520	430	∅ 22 n°12	160							
713 T2 F	550	600	660	445	∅ 26 n°24	350							

800 series Winch drives



Gear units for winch application.

The units of the 800 series are specifically designed for winch applications, and can be easily accommodated within the drum itself.

Available in various gear ratios, units feature heavy duty bearings and an optional failsafe parking or emergency multidisc brake.

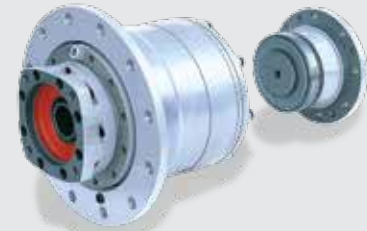

Torque Range

5000 ... 42000 Nm

Line rope range

35000 ... 170000 N

Gear Ratios

21 ... 108

Key Features

- Rotating housing flange
- Rugged construction
- High torque capacity
- High load capacity
- Freewheel for antirun-back device, as an optional

Applicable hydraulic motors

- Flanged axial piston motors
- Orbit motors

Brake

- Hydraulically released parking brake on request

Type	Torque (Nm)
805 W2	5000
806 W2	10000
810 F2	17500
811 W2	27000
813 W3	42000

Type	Max. line rope (N)
805 W2	35000
806 W2	50000
810 F2	85000
811 W2	120000
813 W3	170000



Overall dimensions and technical data

TYPE	RANGE OF RATIOS	MAX. INPUT SPEED	BRAKING TORQUE	MIN. OPENING PRESSURE	WEIGHT
	1:	min ⁻¹	Nm	bar	Kg
805 W2	22 - 53	3000	500 - 750	15 - 25	70
806 W2	30 - 44	3000	700 - 1000	15 - 25	95
810 F2	21 - 46	3000	800 - 1200	15 - 25	160
811 W2	42	2500	900 - 1300	15 - 25	270
813 W3	60 - 108	2500	900 - 1300	15 - 25	310

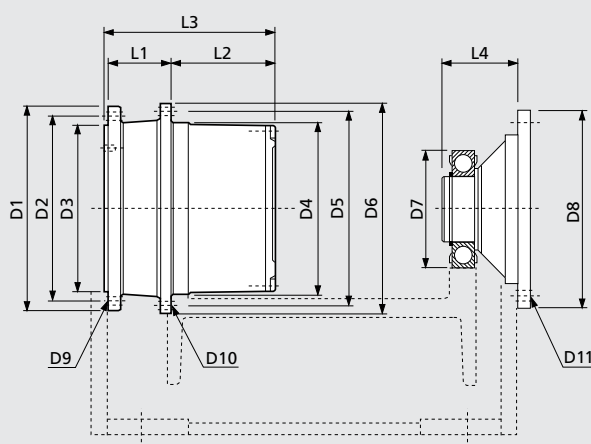

TYPE	D1	D2	D3	D4	D5	D6	D7	D8	D9	D10	D11	L1	D11	L1	L4
805 W2	265	240	215	225	250	270	140	210	M12x1.75 n°16	ø13 n°16	ø13 n°8	75	158	250	95
806 W2	330	300	270	280	315	340	140	210	M16x2 n°12	ø17 n°12	ø13 n°8	100	165	280	95
810 F2	270	240	215	350	375	410	190	320	M16x2 n°18	ø13 n°24	ø19 n°12	25	310	360	110
811 W2	420	325	280	410	455	490	190	320	M20x2.5 n°21	ø22 n°24	ø19 n°12	110	260	390	110
813 W3	420	325	280	410	455	490	190	320	M20x2.5 n°21	ø22 n°24	ø19 n°12	110	275	405	110

OUR QUALITIES



Sharing the value of our work with you.



The development of effective, tailored solutions for a wide range of applications is a fundamental aspect of our work.

We succeed in this because we co-operate closely with our customers, listen to their requests and work with them to improve our own performance.

Bonfiglioli is determined to deliver the best service possible – before, during and after the sale of any of our products – by applying all our know-how, experience, technology, and advanced communication tools. Bonfiglioli works to the strictest standards of quality and safety, as certified by seven different internationally recognised institutes.

We believe in innovation, and back up this belief by dedicating 100 of our people and 5 activity centres to research and development, and by working hand in hand with some of the world's most prestigious universities.

Our work increasingly brings us into contact with other nations and cultures, for which we have the greatest respect and with whom we share a vision of sustainable development based on renewable energy.

This bond of commitment allows us to be an authoritative and reliable global partner for the present and the future.

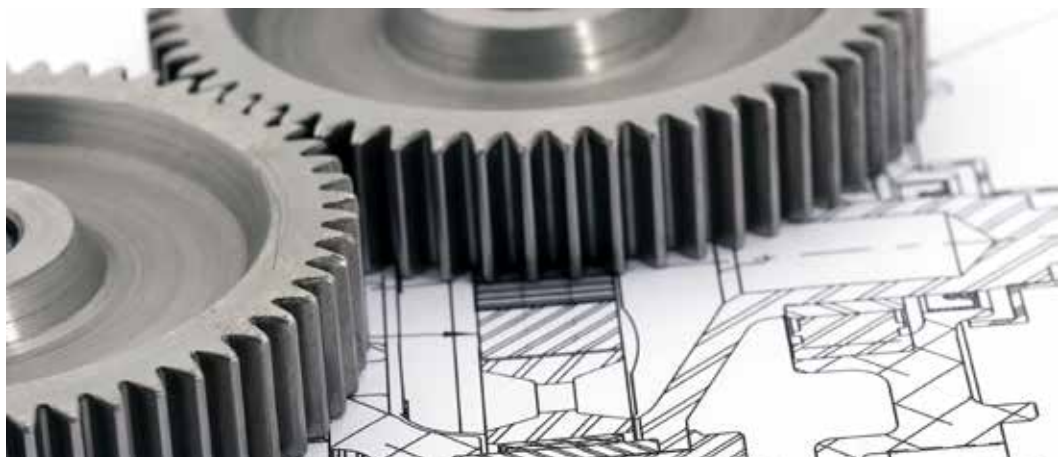

Bonfiglioli Worldwide Presence

Bonfiglioli is located in regions and countries around the world that enable us to provide faster sales and service to customers. Our network includes more than 35 service centers worldwide, with 12 facilities that manufacture and assemble products that are specific to the mining industry.

We are around the world, and around the corner.

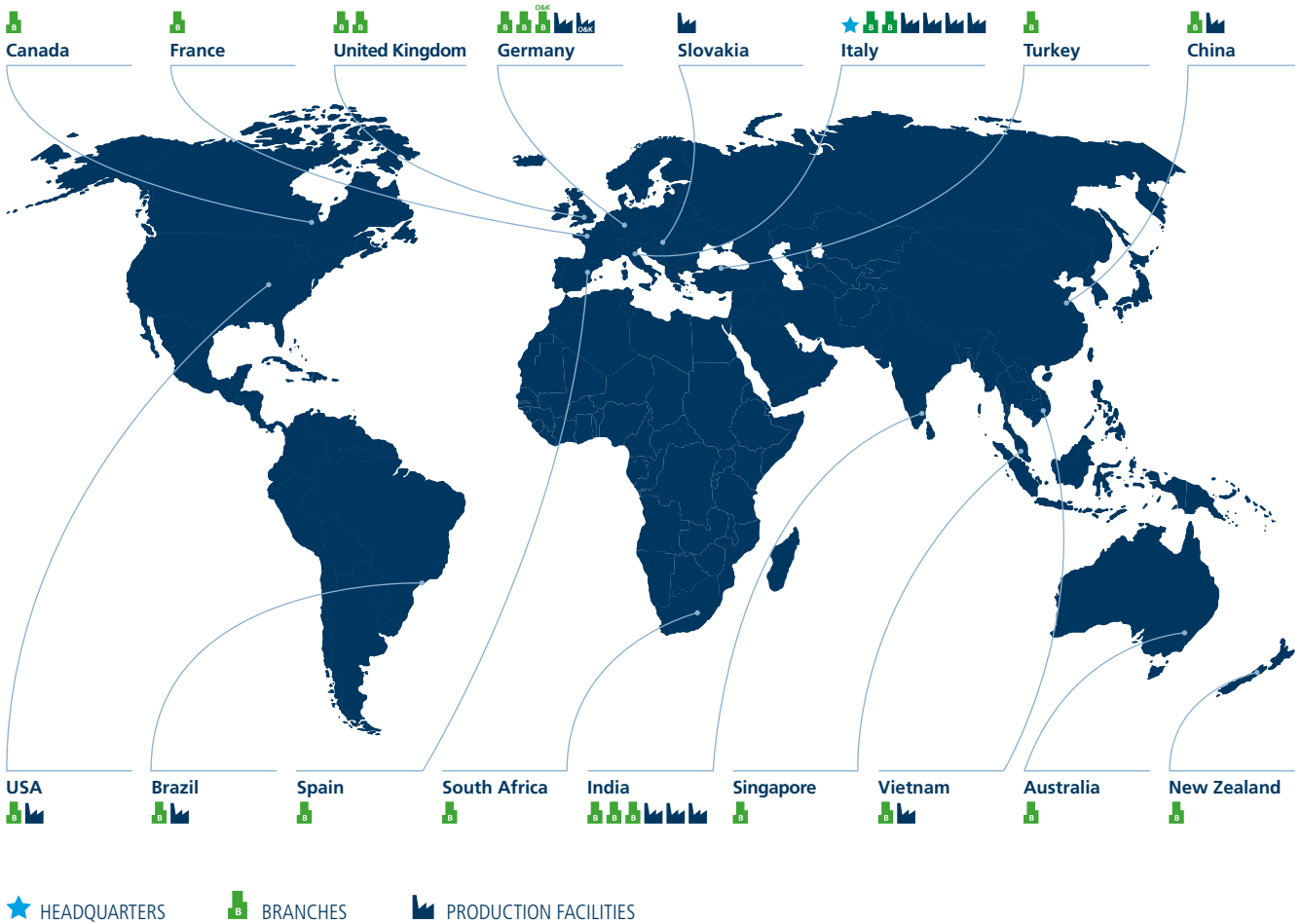

LOCAL SUPPORT



SALES, CUSTOMER SERVICE, WARRANTY, TECH SUPPORT, SPARE PARTS

22 BRANCH OFFICES IN 16 COUNTRIES



WORLDWIDE DISTRIBUTION NETWORK



Bonfiglioli Worldwide Locations

Bonfiglioli Australia

www.bonfiglioli.com.au
2, Cox Place Glendenning NSW 2761
Locked Bag 1000 Plumpton NSW 2761
Tel. (+ 61) 2 8811 8000 - Fax (+ 61) 2 9675 6605

Bonfiglioli Brasil

www.bonfigliolidobrasil.com.br
Travessa Cláudio Armando 171
Bloco 3 - CEP 09861-730 - Bairro Assunção
São Bernardo do Campo - São Paulo
Tel. (+55) 11 4344 2323 - Fax (+55) 11 4344 2322

Bonfiglioli Canada

www.bonfigliolicanada.com
2-7941 Jane Street - Concord, Ontario L4K 4L6
Tel. (+1) 905 7384466 - Fax (+1) 905 7389833

Bonfiglioli China

www.bonfiglioli.cn
Bonfiglioli Drives (Shanghai) Co., Ltd.
#68, Hui-Lian Road, QingPu District,
201707 Shanghai
Ph. (+86) 21 6700 2000 - Fax (+86) 21 6700 2100

Bonfiglioli Deutschland

www.bonfiglioli.de
Industrial, Mobile, Wind
Sperberweg 12 - 41468 Neuss
Tel. +49 (0) 2131 2988 0 - Fax +49 (0) 2131 2988 100
Industrial
Europark Fichtenhain B6 - 47807 Krefeld
Tel. +49 (0) 2151 8396 0 - Fax +49 (0) 2151 8396 999
O&K Antriebstechnik
Ruhrallee 8-12 - 45525 Hattingen
Tel. +49 (0) 2324 2050 1 - Fax +49 (0) 2324 2054 29

Bonfiglioli España

www.tecnotrans.bonfiglioli.com/es-es/
Industrial, Mobile, Wind
Tecnotrans Bonfiglioli S.A.
Pol. Ind. Zona Franca sector C, calle F, nº6
08040 Barcelona
Tel. (+34) 93 4478400 - Fax (+34) 93 3360402

Bonfiglioli France

www.bonfiglioli.fr
14 Rue Eugène Pottier
Zone Industrielle de Moimont II - 95670 Marly la Ville
Tel. (+33) 1 34474510 - Fax (+33) 1 34688800

Bonfiglioli India

www.bonfiglioli.in
Bonfiglioli Transmissions Pvt. Ltd.
Plot No. AC7-AC11, SIDCO Industrial Estate,
Thirumudivakkam - 600 044 Chennai
Tel.: +91 44 2478 1035

Bonfiglioli Italia

www.bonfiglioli.it
Headquarters
Bonfiglioli Riduttori S.p.A.
Via Giovanni XXIII, 7/A
Lippo di Calderara di Reno - 40012 Bologna
Tel. +39 051 647 3111 - Fax +39 051 647 3126
Mobile, Wind
Via Enrico Mattei, 12 Z.I. Villa Selva - 47100 Forlì
Tel. +39 0543 789111 - Fax +39 0543789242
Industrial
Via Bazzane, 33/A - 40012 Calderara di Reno (BO)
Tel. +39 051 6473111 - Fax +39 051 6473330
Industrial
Via Trinità, 1 - 41058 Vignola (MO)
Tel. +39 059 768511 - Fax +39 059 768522
Industrial
Via Sandro Pertini lotto 7b - 20080 Carpiano (Milano)
Tel. (+39) 02 985081 - Fax (+39) 02 985085817
Bonfiglioli Mechatronic Research
Via F. Zeni 8 - 38068 Rovereto (Trento)
Tel. (+39) 0464 443435/36 - Fax (+39) 0464 443439

Bonfiglioli New Zealand

www.bonfiglioli.co.nz
88 Hastie Avenue, Mangere Bridge, 2022 Auckland
PO Box 11795, Ellerslie
Tel. (+64) 09 634 6441 - Fax (+64) 09 634 6445

Bonfiglioli South East Asia

www.bonfiglioli.com
24 Pioneer Crescent #02-08
West Park Bizcentral - Singapore, 628557
Tel. (+65) 6268 9869 - Fax. (+65) 6268 9179

Bonfiglioli South Africa

www.bonfiglioli.co.za
55 Galaxy Avenue, Linbro Business Park - Sandton
Tel. (+27) 11 608 2030 OR - Fax (+27) 11 608 2631

Bonfiglioli Türkiye

www.bonfiglioli.com.tr
Atatürk Organize Sanayi Bölgesi, 10007 Sk. No. 30
Atatürk Organize Sanayi Bölgesi, 35620 Çiğli - İzmir
Tel. +90 (0) 232 328 22 77 (pbx) - Fax +90 (0) 232 328 04 14

Bonfiglioli United Kingdom

www.bonfiglioli.co.uk
Industrial
Unit 7, Colemeadow Road
North Moons Moat - Redditch, Worcestershire B98 9PB
Tel. (+44) 1527 65022 - Fax (+44) 1527 61995
Mobile, Wind
3 - 7 Grosvenor Grange, Woolston
Warrington - Cheshire WA1 4SF
Tel. (+44) 1925 852667 - Fax (+44) 1925 852668

Bonfiglioli USA

www.bonfiglioliusa.com
3541 Hargrave Drive Hebron, Kentucky 41048
Tel. (+1) 859 334 3333 - Fax (+1) 859 334 8888

Bonfiglioli Vietnam

www.bonfiglioli.vn
Lot C-9D-CN My Phuoc Industrial Park 3
Ben Cat - Binh Duong Province
Tel. (+84) 650 3577411 - Fax (+84) 650 3577422



We have a relentless commitment to excellence, innovation and sustainability. Our team creates, distributes and services world-class power transmission and drive solutions to keep the world in motion.

HEADQUARTERS

Bonfiglioli Riduttori S.p.A.

Via Giovanni XXIII, 7/A

40012 Lippo di Calderara di Reno

Bologna (Italy)

tel: +39 051 647 3111

fax: +39 051 647 3126

bonfiglioli@bonfiglioli.com

www.bonfiglioli.com

